

A photograph of two women in hunting attire standing in a field of tall grass. The woman on the left is smiling and looking towards the woman on the right. Both are wearing brown hats and carrying rifles. The woman on the right is also wearing binoculars around her neck. The background shows a line of trees under a clear blue sky.

**ANSCHÜTZ**

EINFACH EINS WERDEN!

Model **1782**

THE **RETURN** OF THE  
CENTERFIRE HUNTING  
REPEATER

**NEW!**







*"A rifle should never cause problems! It needs to function. **Precisely** and **reliably**, under all situations, in all conditions. Rain is no excuse, dirt is no handicap, cold is no reason. ANSCHÜTZ provides the hunter with a solid and reliable hunting bolt-action rifle - the Model 1782."*

**"GOOD HUNTING!"**

1782

## THE NEW DAY

The sky is reddening. Remnants of night-time grey, pale yellow. The morning dew hangs in the air and coats the wood on the hunting stand. Hoping for the first quarry.

An owl heard hours ago, a woodpecker hammers in the distance. The twilight is filled with waiting.

There! A branch moving against the wind! No rapid movement at all - not a word, no noise of any kind! Get your rifle. Time expands. Carefully change your position.

The game shows itself.

Aim. Release the safety catch silently, completely silently. Very good rifle! The correct choice. High-tech without pomp and grandeur, straightforward design, precise and rapid action. The eye looks through the telescopic sight, the finger on the trigger senses the two stage. Infinitely fine trigger adjustment. The stock radiates an intimate feeling and transfers to the body.

Waiting becomes concentration.

## 1782 **MODELS**

RIFLES MADE OF WOOD AND STEEL



1 Slip resistant rubber butt pad

2 German style stock, made of beautiful grown walnut

3 Sliding safety catch

4 Hard-chromed fine-ground bolt with 6 locking lugs

5 Barrelled action milled from solid steel with integrated Picatinny rail

6 ANSCHÜTZ Precision barrel





7 Barrel thread M15x1

8 Studs

9 Match single stage trigger 5082 D, 400 - 1.550g

10 "Fast Release" by integrated magazine release lever in the trigger guard

11 Fast release 3-shot magazine made from sheet steel

12 Non-slip checkering

13 Classic style stock, made of beautiful grown walnut







PRECISION INTERACTION

**MADE OF WOOD AND STEEL**





1782

## **COMPLEX AND SIMPLE**

Nothing convinces one more quickly and substantially than reduction, simplicity, purism - where nothing distracts and everything is pure concentration, every optical effect, every function. Such as with the ANSCHÜTZ centerfire hunting bolt-action rifle 1782. A hunting rifle that, in essence, consists purely of wood and steel. Unpretentious and simple.

It is only with familiarization that one discovers the complexity of the 1782, and is amazed by its precision of modern engineering. Only then does the admiration increase, the owner's pride radiates in the unpretentious yet highly-complex rifle in his hands.

The 1782. A rifle that radiates calm and imparts competence. Welcomed attributes, so important during the hunt.

When we go hunting.

# 1782 **STEEL RECEIVER**

## MADE TO WITHSTAND

Barrelled action made from steel. Purity and quality - classically blued. Securely mated to the stock for outstanding shooting performance. Sturdy and resistant to heat and cold. Highly-precise surfaces that display elegance in design and allow the bolt to slide internally without any resistance. A reliable companion with unmatched precision and function. Timeless perfection!



- The integrated Picatinny rail allows a flexible, simple and sturdy scope mount.



# 1782 **BOLT MOVEMENT**

MOVING, SOFT, PRECISE, QUICK

A bolt movement that never fails to impress. Hard-chromed bolt, fine-ground for silky-soft repeating. Corrosion-protected. Two-row six locking lugs - a reliable, stable detail for the highest level of safety.



Barrel thread M15x1 with thread protector or recessed muzzle



60° bolt throw

Hard-chromed fine-ground bolt

Two-row six locking lug

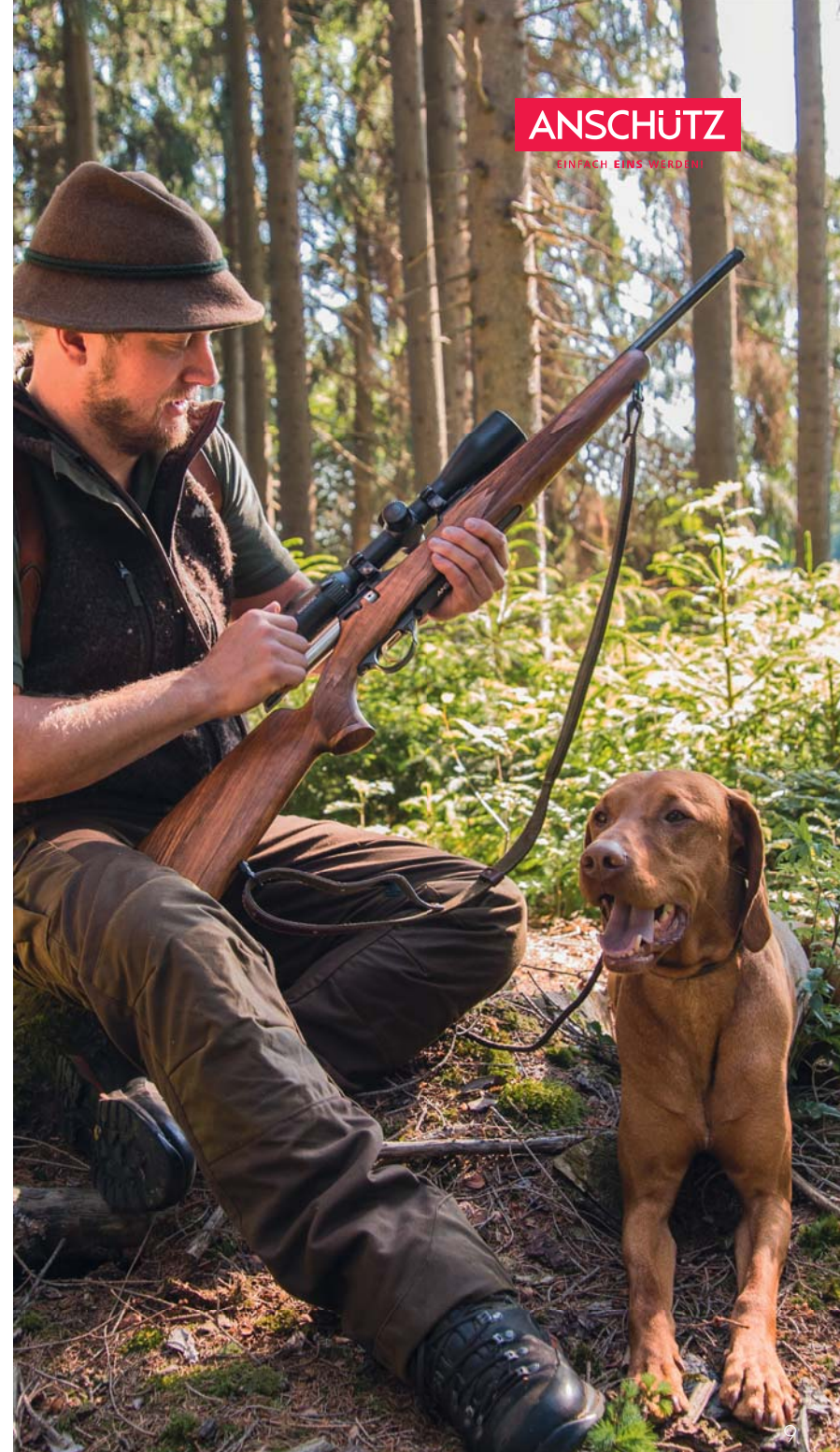

**ANSCHÜTZ**  
EINFACH EINS WERDEN!



# 1782 **TRIGGER**

## PEAK OF THE ANSCHÜTZ COMPETENCE

Precision and refinement from high-performance sports - in summer and winter. Extremely wide adjustment range for the two stage and trigger weight. The location in the rifle with the decisive moment - 50 high-precision parts in harmony in the tightest of spaces. For a single task!

The perfect harmonization between man and rifle. Unparalleled.

**There is nothing better.**

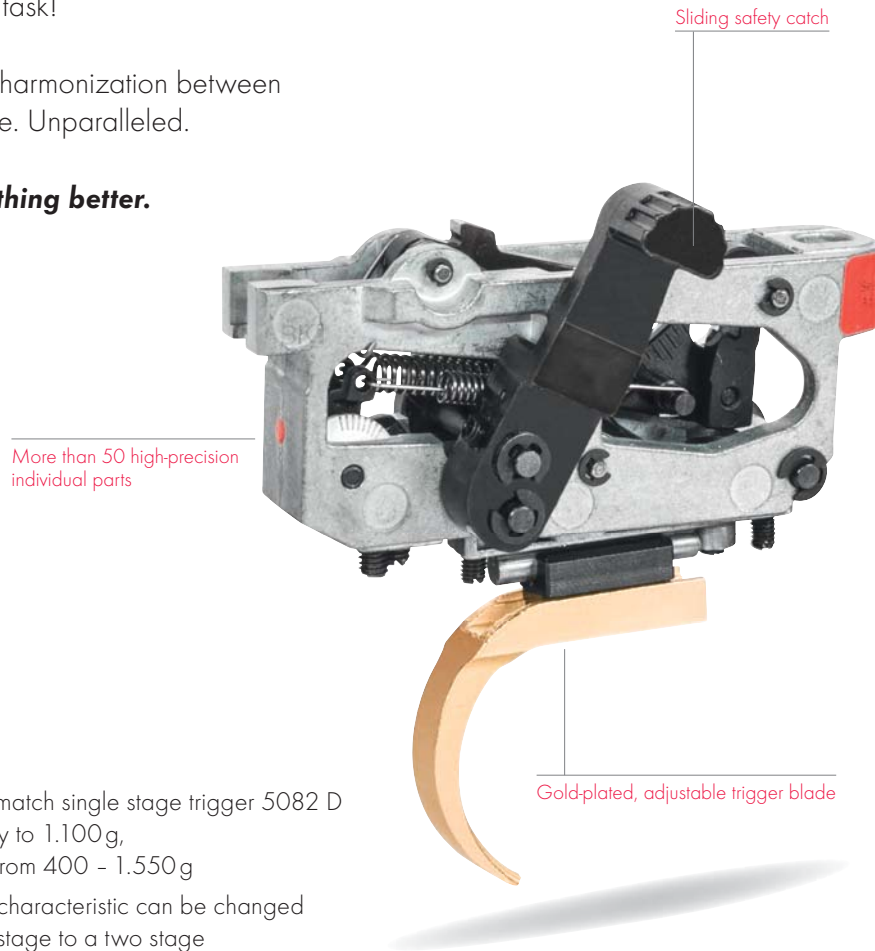

- Adjustable match single stage trigger 5082 D set in factory to 1.100g, adjustable from 400 - 1.550g
- The trigger characteristic can be changed from single stage to a two stage
- Ergonomic and silent safety catch operation





# 1782 **PRECISION** ANSCHÜTZ GUARANTEED

Before a 1782 leaves our factory in Ulm, each rifle is checked for shooting and safety; and then, the repeater receives the official proof house seal.

Before this can happen, we have already manufactured the 1782 so precisely, and assembled it so meticulously, that we are able to give each rifle a guarantee to take with it to the customer - **the ANSCHÜTZ guarantee of precision!**

It means that: Three shots, one after the other, will be a maximum of 28 mm apart. The decisive factor, that makes the guarantee so valuable, is that: The 28 mm are "enclosed". In other words: The outer edges of the hits on the target are no more than 28 mm apart from each other!

28 mm.



Typical 3-shot .308 Win. test fire group at 100 m\*

**For the following calibers, we guarantee, for 3 shots, maximum group sizes\* of:**

.243 Win.....	28 mm
6.5 Creedmoor.....	28 mm
.308 Win.....	28 mm
.30-06.....	28 mm
8 x 57 IS.....	28 mm
9,3 x 62.....	30 mm

\* shot using Premium Hunting Ammunition



**ANSCHÜTZ**  
DURCH EINS WERDEN

*Then as now -  
highest precision in manufacturing barrels!*

*The ANSCHÜTZ barrel specialists working at the special barrel crafting machines in the ANSCHÜTZ factory in Ulm, approx. 1955*



## 1782 **FAST RELEASE** SIMPLE HANDLING, RAPID EJECTION

The magazine holds three cartridges, is made from sturdy sheet steel and is thus insensitive to dust, dirt and water. Convenient handling of the magazine as a result of the handy magazine base.

The magazine, which is located safely and securely in the magazine guide, is particularly easy to remove. Slight pressure with your index finger on the magazine release lever and the magazine slides out of the magazine guide!

**"Fast Release!"**





# 1782 **THE STOCKS** MAKE EACH RIFLE UNIQUE

Due to its qualities, Walnut is chosen from age old forests, then elegantly sculpted to form a balance between beauty and functionality with non slip checkering. Every stock rewards the senses, all are unique and distinctive.

The rubber butt pad absorbs the recoil and holds the rifle securely in the shoulder when aiming.



- Oiled walnut
- Solid aluminum action carrier with additional recoil lug for precise and sturdy bedding of the steel barrelled action
- Magazine release lever integrated in trigger guard





# 1782 MODULAR SYSTEM

YOUR PERSONAL 1782 - ACCORDING TO YOUR WISHES!

## 1. CHOOSE A CALIBER

### .243 Win.

Number of grooves .....6  
Twist rate..... 254 mm



### 6.5 Creedmoor

Number of grooves .....6  
Twist rate..... 203 mm



### .308 Win.

Number of grooves .....4  
Twist rate..... 305 mm



### .30-06

Number of grooves .....4  
Twist rate..... 254 mm



### 8 x 57 IS

Number of grooves .....4  
Twist rate.....240 mm



### 9,3 x 62

Number of grooves .....4  
Twist rate..... 360 mm



## 2. CHOOSE A BARREL LENGTH



Barreled action equipped with  
single stage trigger 5082 D,  
adjustable from 400 - 1.550g,  
trigger weight, adjusted to 1.100g,  
and a 3-shot detachable magazine

### Barreled action without thread

Length of barreled action .....760 mm  
Barrel length.....22.8" (580 mm)  
Muzzle diameter..... 18 mm



Recessed muzzle



### Barreled action with threaded muzzle (M15x1) including thread protector

Length of barreled action .....700 mm  
Barrel length.....20.5" (520 mm)  
Muzzle diameter..... 18 mm



Threaded muzzle M15x1 including thread protector





**Delivery volume:**

Model 1782 configurations will be delivered with a 3 shot magazine, sling swivles and a thread protector (when choosen the barreld action with barrel thread).  
Delivered in the transport rifle MEGA.

**3. CHOOSE A STOCK**

**German Stock, oiled**

Length of pull ..... 360 mm  
Length of stock ..... 820 mm  
Material ..... Walnut



**Classic Stock, oiled**

Length of pull ..... 360 mm  
Length of stock ..... 820 mm  
Material ..... Walnut



Stocks equipped with rubber butt pad, studs, trigger guard and aluminum action bedding

**4. ACCESSORIES**



Sound moderator  
Overbarrel



Sound moderator  
Quick Connect



Magazine  
5 shot



Magazine, replacement  
3 shot



Sling swivles



# 1782 TECHNICAL SPECIFICATIONS

Depending on the selected configuration, the technical specifications of your model 1782 will be different.

The total weight is between 3.400 - 3.600g,  
The total length is between 1020 - 1080 mm.

## CONFIGURATION EXAMPLES

### Model 1782, 20.5" (520 mm) barrel, Classic stock

Total length ..... 1020 mm

Total weight, approx. .... 3.400 g

### Model 1782, 20.5" (520 mm) barrel, German stock

Total length ..... 1020 mm

Total weight, approx. .... 3.400 g

### Model 1782, 22.8" (580 mm) barrel, Classic stock

Total length ..... 1080 mm

Total weight, approx. .... 3.600g

### Model 1782, 22.8" (580 mm) barrel, German stock

Total length ..... 1080 mm

Total weight, approx. .... 3.600g

## Magazine

Number of shots..... 3

Total weight, approx. .... 145 g

## Trigger 5082

Trigger adjusted ..... Single stage trigger

Weight adjusted to..... 1.100 g

Range of adjustment ..... 400 - 1.550 g

Trigger adjusted ..... Two stage trigger

Weight adjusted to..... 1.100 g

Range of adjustment..... 400 - 1.550 g

Weight approx. .... 170 g

## Caliber

**Caliber ..... .243 Win.**

Number of grooves..... 6

Twist rate ..... 254 mm

**Caliber ..... 6.5 Creedmoor**

Number of grooves..... 6

Twist rate ..... 203 mm

**Caliber ..... .308 Win.**

Number of grooves..... 4

Twist rate ..... 305 mm

**Caliber ..... .30-06**

Number of grooves..... 4

Twist rate ..... 254 mm

**Caliber ..... 8 x 57 IS**

Number of grooves..... 4

Twist rate ..... 240 mm

**Caliber ..... 9,3 x 62**

Number of grooves..... 4

Twist rate ..... 360 mm

## Barreled action without thread

Total length ..... 760 mm

Barrel length..... 22.8" (580 mm)

Muzzle diameter ..... 18 mm

Weight approx. .... 2.350 g

## Barreled action with thread

Total length ..... 700 mm

Barrel length..... 20.5" (520 mm)

Barrel thread ..... M15x1

Muzzle diameter ..... 18 mm

Weight approx. .... 2.290 g

## Classic stock, oiled

Total length of stock..... 820 mm

Length of pull..... 360 mm

Weight approx. .... 1.300 g

Butt plate..... Rubber butt pad

## German stock, oiled

Total length of stock..... 820 mm

Length of pull..... 360 mm

Weight approx. .... 1.300 g

Butt plate..... Rubber butt pad



**“Creativity” is the result of curiosity applied to a subject or task.**

“When a new rifle is created at ANSCHÜTZ, such as the hunting rifle 1782, there will have been dozens of creative moments and hundreds of decisions on the path to perfection. This can never be the work of just a single person - it is teamwork in perfection. Absolutely unthinkable without the curiosity and motivation of each and every co-worker! Every one of them is a competence center at ANSCHÜTZ.

Even though we are justifiably very proud of the finished product, our 1782: In principle, the route taken is the more important part. You can only achieve the goal yourself, in the process we always re-learn something and learn something new. The goal, however, sometimes has something final about it, and is thus “uncreative”.

I would like to thank our employees for their creativity! And I would like to hope that you can detect how much creativity has been realised in the new centerfire hunting rifle 1782!”

*Maximilian Anschütz*

**Maximilian Anschütz**  
6. Generation

At ANSCHÜTZ we live the hunt.





ANSCHÜTZ 1782

**THE RIFLE FOR HUNTING**





# 1782 CONFIGURATION

SELECTABLE COMPONENTS		Selection
CALIBER	.243 Win.	<input checked="" type="checkbox"/>
	6.5 Creedmoor	<input checked="" type="checkbox"/>
	.308 Win.	<input checked="" type="checkbox"/>
	.30-06	<input checked="" type="checkbox"/>
	8x57 IS	<input checked="" type="checkbox"/>
	9,3x62	<input checked="" type="checkbox"/>
BARRELS	22.8" Barrel (580 mm) with recessed muzzle	<input checked="" type="checkbox"/>
	20.5" Barrel (520 mm) with thread M15x1 and thread protector	<input type="checkbox"/>
STOCKS	Classic style stock, oiled	<input checked="" type="checkbox"/>
	German style stock, oiled	<input type="checkbox"/>
RECOMMENDED ACCESSORIES	Magazine 3 shot, replacement	<input type="checkbox"/>
	Magazine 5 shot	<input type="checkbox"/>
	Thread protector M15x1, replacement	<input type="checkbox"/>
	Target knob Ø 20 mm, made out of steel	<input type="checkbox"/>
	Barrel weight, 365 g, for thread M15x1	<input type="checkbox"/>
	Sling swivles, replacement	<input type="checkbox"/>
	Sound moderator Quick Connect, depending to caliber	<input type="checkbox"/>
	Sound moderator Over Barrel, depending to caliber	<input type="checkbox"/>

Included in the basic price

Optional - with surcharge



# ANSCHÜTZ

EINFACH EINS WERDEN!

**J.G. ANSCHÜTZ GmbH & Co. KG**  
**Jagd- und Sportwaffenfabrik**

Daimlerstraße 12 · 89079 Ulm / Germany  
Fon +49-(0)731-40 12-0  
Fax +49-(0)731-40 12-700  
[www.anschuetz-sport.com](http://www.anschuetz-sport.com)  
[www.facebook.com/OfficialAnschuetz](https://www.facebook.com/OfficialAnschuetz)  
[www.youtube.com/AnschuetzGmbH](https://www.youtube.com/AnschuetzGmbH)  
[www.instagram.com/AnschuetzGmbH](https://www.instagram.com/AnschuetzGmbH)

Your dealer:

*"ANSCHÜTZ researches and produces on a high level of technology. In our creations, we draw on the never outdated source of traditional craftsmanship.*

*In the end, tradition means consistency and steadfastness, not losing your head when it comes to the multitude of perhaps tempting but short-lived trends. And so, we see ourselves as the guardians of an excellent "Made in Germany" concept:*

*We manufacture nearly all the components of our rifles by ourselves. The employees of ANSCHÜTZ are aware of the responsibility bound up in each individual step of production and are proud to bring with them their experience and specialist knowledge. This is the foundation of the first-class quality of ANSCHÜTZ!*

*ANSCHÜTZ rifles are not just simple production firearms. They are individual masterpieces that are designed, assembled and tested with the utmost attention to detail."*

*Jochen Anschütz*  
**Jochen Anschütz**  
President

